

PHYSICS BASED SIMULATION OF NIGHT VISION GOGGLES

Liz Martin, Ph.D.

Senior Research Psychologist

Air Force Research Laboratory/Warfighter Training Research Division (AFRL/HEA)

&

Jeff Clark

Senior Systems Engineer

Link Simulation & Training

Introduction

Night vision goggles (NVGs) are a head mounted, head steered sensor designed to allow an aviator to operate at night with increased operational capability and situation awareness. NVGs greatly enhance an aircrew's ability to conduct night operations and are used extensively in both rotary and fixed wing operations. NVGs provide an intensified image of scenes illuminated by ambient energy that exists in the night environment. NVGs (generation III) amplify energy in a certain portion of the electro-magnetic spectrum 2,000-7,000 times. They are sensitive in the red and near infrared (approximately 600-900 nanometers[nm]). In fact, there is little to no overlap in the ranges of sensitivity of the human eye and NVGs. The resulting imagery has some special characteristics that influence human perception and operational employment that drive a requirement for realistic imagery to support simulation-based training and mission rehearsal.

NVGs: How they work

In order to better understand the nature of the imagery, it is helpful to understand some of the aspects of the goggles and how they work. NVGs are very sophisticated and complex systems, and a complete description is beyond the scope of this paper. The following is an overview of the basics that are most relevant. The primary components of an image intensifier tube module include a photocathode, microchannel plate, and phosphor screen. (See Fig. 1). The intensification process begins when electromagnetic energy from a scene is focused as an image on the photocathode. The photocathode releases

an equivalent image of electrons, which are accelerated across a short gap to the microchannel plate (MCP). The microchannel plate is a structure containing millions of parallel microscopic channels or tubules which open on the front and back faces of the plate and which have an electrical potential gradient along their length. As the electrons enter a microchannel, they collide with the inner wall of the channel. Each collision, in turn, releases still more electrons. Each of these electrons strikes the wall further down the channel (due to the angle of the channel), and each collision releases still more electrons. Influenced by the potential gradient, the electron multiplication process continues down the length of each channel until the electrons exit the microchannel plate. The electrons, greatly increased in number, then are accelerated across a small gap by a high voltage field and strike a given part of the phosphor screen, causing it to glow. The luminance of the image on the phosphor screen is many times brighter than that of the image focused on the photocathode. The response of the system is modulated by a gain function, which serves to increase low light level performance and protect the phosphor screen in exceedingly bright conditions. Gain refers to the ratio of output to input, i.e., the amount of energy the intensification process produces relative to the amount of energy that entered the intensification process. A goggle has circuitry that determines the amount of energy entering the intensification process, which then automatically

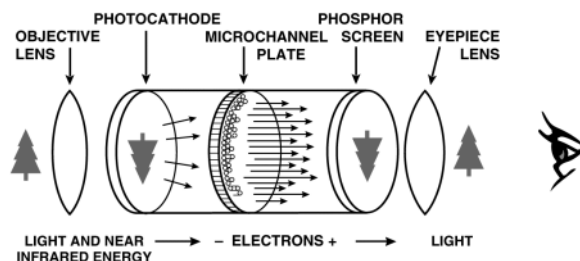

Fig. 1 Image intensification process

controls the level of intensification needed to produce images of consistent brightness over a wide range of illumination levels. As illumination decreases, NVG gain increases. Maximum NVG gain occurs at approximately 1/4 moon illumination. Therefore, illumination levels less than 1/4 moon result in decreased image contrast. Image degradation caused by this process can be very subtle and lead to problems for aircrew. The system attempts to maintain an average screen luminance and has an auto-brilliance control to protect it under extreme illumination conditions.

Aviators' NVGs also contain filters (a coating on the inside of the objective lens) that block entry of certain wavelengths. These are called minus blue filters and are either at 625nm (Class A filter) or at 665nm (Class B). Generally, Class B filters are used in cockpits which have colored displays. NVGs also can have a "notch" filter that permits a small amount of energy to pass through that is otherwise blocked by the filters. This is commonly referred to as a "leaky" green filter and allows direct viewing of the head-up-display (HUD). NVGs have a number of adjustable components that can be used to optimize the image alignment for each user. These include adjustable objective lenses, vertical tilt, fore and aft eye relief, interpupillary distance adjustments, and adjustable diopter eyepieces. They weigh approximately 1.8 lb. Most current models have a 40 deg nominal field of view (FOV) and use a P-43 phosphor with a peak at 550nm. Earlier NVG models used P-20 or P22 phosphor.

The result is a monochromatic, green, binocular image with a 40-degree FOV. In general, the intensification process does not distort the imaged scene through magnification or minification. The image contains a certain amount of noise as the result of random electronic activity. Under extremely low levels of ambient illumination, the image is largely noise. The number of tubules in the microchannel plate largely determines the resolution of the goggles. However, the visual acuity achievable is a function of the ambient illumination and contrast in the scene. The visual acuity envelope for most current NVGs is 20/25 (high illumination and high contrast) to 20/45 (starlight equivalent and low contrast) when tested through clear air. In practice, NVG imagery is not viewed through clear air but through a windscreen or canopy, which will degrade the achievable visual acuity.

There are a number of anomalies that can occur with NVGs. The most noticeable is called a "halo" (also referred to as a "bloom") which is caused by the intensification of a bright light source. Halos are seen as a circular area of brightness which can vary in intensity and often appears with concentric circles of varying brightness. The halo is a two dimensional effect caused by an elastic rebound of electrons

hitting the structure of the microchannel plate (rather than a tubule) and, subsequently, entering a tubule removed from the original location. The size of halos is a function of the spectral characteristics and intensity of the source. The brightness is a function of the light source and the ambient illumination conditions. The same light source can have a halo that appears quite different depending on the ambient illumination conditions due to the modulation of the goggle gain response. Since halos are a 2-D effect, occurring in the goggle, they do not change size as a function of distance.

Illumination Sources. There are a number of sources of illumination producing energy within the range of NVG sensitivity (See Fig. 2). The obvious and most significant one is the moon. Starlight also contributes to the near-IR energy level. (Although there are only about 8,000 stars visible to the unaided eye, many more are visible with NVGs). There are chemical reactions in the upper atmosphere that account for the majority of near-IR energy present on a moonless night. Aurora and Zodiacal lights are minor sources of near-IR energy. Ambient light from the sun following sunset and before sunrise is a significant modulator of the image. The effect called "skyglow" is caused by solar light once the sun is below the horizon. Sunset skyglow lasts well after sunset in middle latitudes and much longer in certain northern and southern latitudes. Unlike sunset skyglow, sunrise skyglow does not have an obvious effect on NVG performance until fairly close to official sunrise. (The difference has to do with the length of time the atmosphere is exposed to irradiation of the sun.) There are numerous sources of artificial light including city lights, industrial sites, fires, flares, searchlights, reflected cultural lighting and ordnance explosions which have dramatic effects on NVG images.

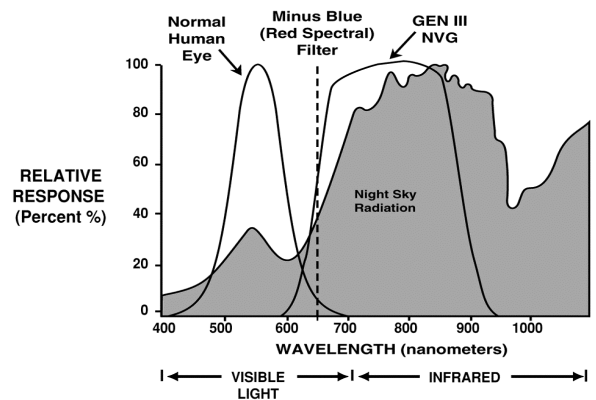

Fig. 2 NVG Response

Core Requirements

In order to define exactly what is needed for effective simulation to support mission training and rehearsal, a series of meetings with experienced users of NVGs from the US Air Force, Navy, and Army were conducted in which a “core set” of NVG characteristics were defined. Since these users came from different weapons systems with different missions, it was agreed to define this core set as those which would be common across the spectrum of airframes and missions. (It was recognized early on that each community might have a set of mission specific requirements that were critical to their application.) The following is that set of core requirements.

- 1) Full range of night sky illumination from overcast starlight to full moon. This means having an accurate NVIS (energy to which night vision imaging systems are sensitive) radiance to NVG image luminance mapping function. The range of night sky energy (not including energy from cultural sources), in NVIS units, spans over two orders of magnitude.
- 2) Effects of Light Sources. This refers to accurately capturing the response of the goggle to the wide variety of natural and artificial in terms of gain response, image luminance, scene contrast, and changes in acuity. It also refers to these effects when the light sources are within and outside the field of view of the goggle.
- 3) NVG characteristics. This refers to having the correct field of view, color, and resolution and well as being able to produce the two dimensional effects of halos, tailing, scintillation, and veiling glare. In the case where the imagery might be produced by total simulation, it captures the requirement to have the same form, fit, and function (weight, center of gravity, and adjustments described above) of the actual NVG reproduced in a display device.
- 4) Accurate surface reflectivity. This refers to having the correct material albedo (the relative reflectivity of a material in the sensitivity range of the NVG) with the correct NVG display luminance for that material.
- 5) Realistic “out the window” night scene. This means that appropriate luminance levels and scene detail of the night scene as viewed with the unaided eye, including a star pattern, are required.
- 6) Shadows. The requirement was for lunar shadows.
- 7) Weather effects. This includes clouds with appropriate effects on goggle image, varying visibility ranges, and lightning. Light reflected from clouds was included in this category.
- 8) Obscurants. This includes the effects of blowing dust and snow as well as smoke. It was felt important to have at least 2 types of smoke (wood and oil burning) effects.
- 9) Realistic gaming area. It was decided that 100nm viewing distance would be the goal and that 30nm was the minimum acceptable.

There are a few questions that might be raised after considering this list of user defined requirements such as, do they really need all those things? Or how can a real time simulation possibly capture all of those requirements? We believe the answer to both questions is a very definite **yes**. In an attempt to illustrate the rationale underlying these requirements, the following section will illustrate applications. The remainder of the paper will focus on how to achieve these effects with simulation.

Lunar phase, azimuth and relative position are all very critical factors influencing image quality and operational capability. For example, when the moon is on the same azimuth as the flight path, and low enough to be within or near the NVG field of view, the goggle gain is driven down, reducing image detail and contrast. The blooming effect from the moon may be large enough to fill the entire image. Once the moon is less than 20% above the horizon, the atmosphere begins absorbing more lunar energy resulting in less image detail. Therefore, a low angle moon may have an adverse impact even when it is behind the aircraft and not in or near the NVG field of view. Even a moon higher in the sky can affect performance. If the moon is at 60 deg above the horizon in front of the aircraft, it is not likely to cause a problem when flying straight and level. However, the moon may become a factor when the nose is pulled up to cross a ridgeline or to begin a delivery maneuver. The location of the moon, even when at a high elevation relative to the horizon, may determine the initial roll-in direction for any maneuver and should be considered during mission planning.

Shadows are another effect that impact image quality and performance. They may be a help or a hindrance depending on circumstances. Nighttime shadows contain very little energy for goggles to use in forming an image. Consequently, image quality within a shadow will be degraded relative to that found outside the shadowed area. When within a shadow, terrain detail can be significantly degraded, and objects can be much more difficult, if not impossible, to locate. When flight into a shadow occurs, the NVG gain will automatically increase. In addition to the reduction in image detail, this will result in a light source becoming even more of a nuisance than when flying outside of the shadowed area. For example, when flying in a valley under high illumination conditions, a single car's

headlights may not cause much blooming in the NVG image. However, if flight into a shadow occurs, the bloom from the headlights will be intense and may necessitate a change in aircraft heading to avoid the adverse effect. Loss of terrain detail is, perhaps, one of the most important effects. During flight under good illumination conditions, a pilot expects to see a certain level of detail. When flight into a shadow occurs, the loss of terrain detail may not have been immediately noticed (especially if the pilot was preoccupied with other matters such as radar, communications etc.). The pilot may begin a descent in order to obtain more detail. The result could be disastrous. Shadows created by clouds may resemble bodies of water when viewed at a distance. Quickly flying in and out of these shadowed areas can lead to rapid changes in NVG gain, which can be quite distracting. Shadows can also be very beneficial. In areas where there is not a lot of varying albedos, they may provide most of the contrast in the scene. Shadows alert aircrew to subtle terrain features that may not be otherwise noted. Shadows also play an important role in object detection. An object may blend in with the background whereas the shadow of the object may provide good contrast. The shadows of man-made objects are sometimes easily recognizable when among the shadows of natural materials, allowing more accurate detection at greater ranges. Shadows are also used in threat masking. It is difficult for aircrew to see much from within shadows, it is also difficult for the threat to see. Shadows may be an aid or a hindrance during NVG operations, but they are important, and it is important for aircrew to understand and experience these effects in order to accomplish proper mission planning and to anticipate them during flight.

There are many sources of artificial light that affect the NVG image and aircrew in a variety of ways, some beneficial and some adverse, but all important. Ordnance effects are critical in combat training applications. Ordnance will have varying effects depending on whether it is from the host aircraft, from another aircraft or from ground based locations. Forward firing ordnance will have an immediate adverse effect on the NVG image due to the blooming that will disappear once the offending light source is stopped or well away from the aircraft. Secondaries and fires may drive NVG gain down to a point where all detail is lost. Smaller and less concentrated sources may mask important details due to blooming effects. One of the real advantages of using NVGs during combat is the ability they give the aircrew to detect threats and determine their position at great ranges (one of the drivers of the large gaming area requirement). Cultural lighting is a very significant factor for NVG imagery and performance. Because NVGs can detect light sources at great distances, cultural lighting aids in locating any number of important things such as a city

or even a cigarette! The presence of headlights helps locate a highway, the motion of light on the front of a train helps locate a railroad. Cultural lighting may help illuminate the sides of hills on dark nights, especially in hilly or mountainous terrain. The obvious negative effects include gaining down when in close proximity to a city, whether the lights are in the goggle field of view or not. Reflected cultural lighting can be very beneficial, especially when low illumination conditions exist and, in particular, when there is a cloud cover. NVG performance may be improved enough to conduct night operations that may not otherwise be possible because the actual illumination may be much higher under the overcast.

The types of terrain and associated contrasts have a lot to do with NVG image and the amount of detail, particularly in areas where there are few cultural features. It is important to demonstrate and experience high and low illumination and high and low contrast. Any area containing varying albedos will likely increase the level of contrast in the image, thus enhancing detail. It is important to recognize that the relative contrast relationships present in the daytime may be reversed or significantly different when using NVGs. This is primarily due to the reflectivity of materials in the near-infrared not visible to the unaided eye. These changes can be confusing to aircrew. Most areas contain a majority of medium to low contrast scenes, with little high contrast information. An NVG provides good imagery in a wide range of illumination levels, but is designed to be very responsive during periods of low illumination. As a result, the image of a low contrast area may appear to contain even less detail during very high illumination conditions (e.g., full moon).

Another factor, embedded in the rationale for the core requirements, is the need to be able to produce situations that are known to be conducive to misperceptions and illusions. Most of the misperceptions and illusions noted while wearing NVGs are the same as those experienced during daytime flight, but made worse by NVG design limitations and factors affecting image quality (e.g., reduced visual acuity, limited field of view, appearance of light sources, monochromatic image and flat plate display). There are also external factors that need to be considered in the simulation that influence the likelihood that misperceptions or illusions will occur. These factors include the illumination level, the reduced contrast, and the moon position. The most common illusions include depth perception and distance estimation errors, terrain contour misperceptions, undetected or illusory motion, aircraft attitude misjudgments, and undetected meteorological conditions. The latter is somewhat unique to NVG operations in that NVG imagery is not affected by certain types of moisture conditions such as

light rain or fog (which would be clearly visible to the unaided eye during daylight). This is because near infrared energy will pass through light moisture more easily than through the visible wavelengths. When conditions worsen to a point that the density and size of the particles block the near infrared energy, the image will be significantly degraded and contain mostly noise. Thus, it is possible to gradually and unknowingly, enter deteriorating conditions and, then, rather suddenly, have no usable image whatsoever.

Another of the core requirements was to present the out the window night scene as it would be viewed with the unaided eye. This is important for two reasons: providing appropriate peripheral cueing when NVGs are in use and providing accurate unaided night imagery when the NVGs are not in use, such as when flipped up in the stowed position. This often happens during certain phases of the mission such as aerial refueling, takeoff, and landing.

Implications for Visual Simulation

The above discussion is not comprehensive, but should serve to show why the core requirements are important. Implicit in much of this, is the need to present the aircrew with the same difficult and complex visual environment as faced in flight. In most cases, they are important to both mission training and mission rehearsal. Now, the question becomes how best to capture these requirements in real time simulation.

Stimulate Approach. Most existing operational systems that attempt to do NVG simulation take an approach that involves stimulating actual NVGs with an external display device. For convenience, we refer to that as the “stimulate” approach. The stimulate approach has been considered attractive for several reasons.

- 1) Accurate representation actual NVG **Form, Fit, and Function** has always been considered a requirement by users. The simplest way to accurately represent the sensor is to use the actual sensor.
- 2) It is typically assumed that stimulating real NVG’s provides the most **realistic sensor effects** possible.
- 3) An actual NVG is a **less expensive display device** than a high fidelity helmet mounted display (HMD).

However, the stimulate approach fails to meet any requirements other than form, fit, and function. The most significant challenge with the stimulate approach is the inability to capture the full dynamic range of the scenes, both intra-scene and inter-scene range. The intra-scene range can easily span 3 orders of magnitude and the inter-scene can span 10 orders of magnitude. No existing display device can provide this range of

capability, thus, there is no way for the goggle to perform its job of making an image that represents the intended environment. Additionally, most image generation systems do not provide for the capability to material classify all the materials modeled in the scene, which is necessary in order to get the albedos and contrast effects which underlie many of these requirements. An additional drawback to the stimulate approach is the inability to provide the night scene as seen by the unaided eye. The display, when viewed with the unaided eye, is a very unnatural looking scene because the color tables and gamma functions of the displays have been modified in an attempt to stimulate the goggle in certain ways.

There are other issues associated with the stimulate approach which may have adverse consequences, such as unequal viewing distances across the display (not an issue for infinity optics systems), the requirement for NVG compatible cockpit lighting and a light tight environment, incorrect eye point (most common with multi-place aircraft), and limited field of view in the display (which then limits the field of regard for NVG use). These factors may or may not be evidenced in a given system. Nevertheless, they need to be considered.

Rationale for Physics-Based Simulate Approach. Advances in image generation technology and physics based simulation have had a significant impact on the simulate versus stimulate question. Advantages of simulate over stimulate include:

- 1) By simulating the device, it is possible to simulate the response of the NVG at the **computational dynamic range** of a computer rather than relying on the actual NVG to be stimulated by the limited dynamic range of the OTW display device. This actually allows for **greater realism** with regard to sensor effects such as halos, gain, and noise.
- 2) As the line between training systems and mission rehearsal/preview systems begin to thin, realism in sensor imagery is becoming a requirement. Settling for green luminance texture maps based on the daytime texture maps offers little NVG-specific training or rehearsal benefit. **Realistic luminance, contrast, and resolution is not possible without physics based material response.**
- 3) Using actual NVGs in a training system poses many challenges with regard to the configuration of **displays**. If the OTW display system is to be used to stimulate NVGs, it is typically adjusted to compensate for low intensities in the NVG sensitive bands. Specifically, red channels are commonly turned up to a level that makes for an unrealistic unaided OTW scene. When simulating NVGs, it is possible to present **very realistic unaided OTW**

scenes. Another challenge in the area of displays is the fact that NVGs are very sensitive to focal length. A slight change in focal distance has a significant impact on visual acuity. For this reason, the **stimulating display must be equidistant from the eyepoint for the entire field of regard.** To mitigate this issue, most training systems utilizing the stimulate approach have used domes, sacrificing resolution and brightness that are so critical to NVG training. Other configurations have attached head-tracked mini-CRT displays on actual image intensification tubes. Of course, the modified weight, CG, and mounting apparatus make it impossible to meet the form, fit, and function requirement that has been clearly mandated by the user. Together, these issues significantly diminish the potential usefulness of a training system that relies on the stimulate approach. Considering recent availability of NVG HMD technologies, it is possible to achieve better combinations of resolution, brightness, and contrast with the simulate approach while still escaping the limitations imposed by display technologies mentioned above. Using HMDs driven by simulation offers other advantages with regard to display configurations. For example, systems based on the simulate approach enjoy **unlimited field of regard** in the NVG channel, whereas the field of regard in the stimulate approach is limited to the dimensions of the OTW display. Another benefit is that HMDs provide more flexibility in the **number of eyepoints** utilized in a training system. In order to stimulate NVGs at multiple crew stations, it would be necessary to have displays equidistant from multiple eyepoints (which is very expensive or impossible) or infinity optics displays.

- 4) There are significant preparations needed in order to use real NVGs in a training system. First, the cockpit must be modified for **NVG compatible lighting.** Second, display system and structural nature of the system must allow for a **“light-tight” environment.** These burdens, alone, burn any savings gained by purchasing real NVGs over an HMD.

Other rationale for physics based approaches lie in the fact that industry is making it more and more feasible. A demand for high performance 3-D image generation in the home and office has created a new market for graphics hardware manufacturers to exploit. The benefits of mass production have already had an impact on price at what the training systems community would call the low-end. However, a less expected, and more compelling, trend has become evident that has the potential to impact performance at the high-end of visual simulation. Some manufacturers are promising systems that will surpass many high-end systems in traditional metrics such as polygon throughput and pixel fill rate. Others will deliver systems with complex

lighting capabilities which, if leveraged by the training systems community, will allow for very convincing out the window and sensor simulations. To take advantage of these trends, it will be desirable to develop a portable, scalable, modular sensor simulation architecture. Modularity is desired so that sensor simulation codes are self-contained, independent of the image generator (IG), and may be developed, maintained, and enhanced at any classification level without the modification of other subsystems. In particular, IG subsystems are realizing significant technology enhancements on frequent manufacturing turns compared to sensor technology. Keeping sensor simulation at the state of the art will require constant integration to new (and moving) IG targets if we continue with the “old” model of sensor simulations that are embedded into particular IGs. Conversely, it will be attractive to have an architecture that allows insertion of the latest IG technology with little integration effort. Furthermore, while sensor technology is much slower to evolve than IG technology, there are still many different flavors of fielded sensors. For example, there are currently more than six models of Gen III NVGs used in aviation application. This fact, along with the trend toward more elaborate advanced, fused sensor technologies, makes it desirable to have the capability to insert new sensor models quickly and efficiently.

Advances in HMD technology are having an impact as well. Achieving NVG form, fit, and function within a simulation display device has been demonstrated. By mounting high resolution, miniature CRTs within an actual NVG shell, the weight, center of gravity, adjustments (except for the objective lens), and mounting mechanisms are preserved. The CRTs use P-43 phosphor as in the actual NVG, correctly matching color and persistence. Current systems are capable of resolutions as high as 1350x1350 pixels driven in a non-interlaced mode. While this resolution does not capture the high end of current NVG performance when used in clear air and high illumination and contrast conditions, it does capture the functional visual acuity measured in operational flight conditions.

Description of NVTS Approach

NVTS Architecture

Night Vision Training System (NVTS) describes an architecture for physics-based night vision goggle simulation. The architecture relies on hardware and software components developed at AFRL/HEA, Mesa, to meet the requirements defined by subject matter experts. **SensorHost** is an Intel based, Linux host that performs all physics and NVG specific computations for the NVTS NVG simulation. The SensorHost system

maintains frame-by-frame communication with the IG via the **SensorHost ICD** (see Appendix) over an ethernet connection. A second key device in the NVTS architecture is the **NVTS Video Processor (NVP)**, a video processing system that is connected between the IG and the HMD and is capable of capturing mean pixel value off of the IG video at the target screen resolution and target frame rate. The NVP is also capable of applying a gain to the IG video and injecting noise into the IG video as specified by the **SensorHost**. All data including video mean and parameters for gain and noise injections flow between the video processing system and the **SensorHost** via RS-232 link. Fig. 3 shows the NVTS architecture as connected in the AFRL proof-of-concept. At AFRL/HEA it was determined that there was sufficient bandwidth on the visual network (between the cockpit and the IG) to facilitate **SensorHost** communication, but some sites may choose to dedicate a separate network for this connection.

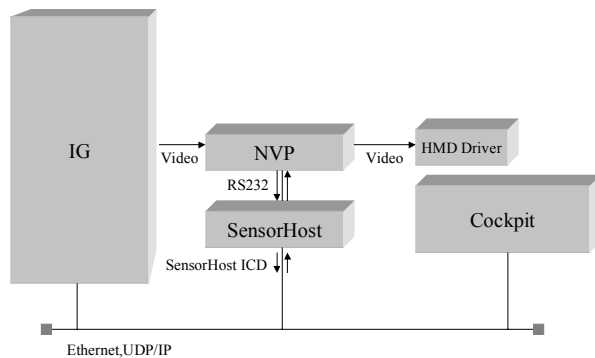

Fig. 3 NVTS Architecture

NVTS Algorithm in Brief

Assumptions and Required Data.

- 1) There exists data describing the radiometric flux per unit area, or flux density incident to the earth's surface (irradiance) for all lunar scenarios we wish to simulate. In particular, as illuminance is the measure of photometric, or visible flux density, we are interested in the flux density in the wavelengths to which NVGs are sensitive. This measure is known as NVIS Irradiance (NI). Geospecific measurements of NI are currently being collected by the NVG Team at AFRL/HEA (see Fig. 4).
- 2) There exists an IG system that is capable of rendering material responses as specified by an external SensorHost through an agreed communication protocol. Scenes are rendered in 3D from a high-resolution terrain material and terrain elevation

database. Frames are rendered by modulating the material response by the dot product of the terrain surface normal and the vector to the illuminator at every spatial sample at 60 frames/second. In the case of NVG, which is sensitive to visible and near infrared "light", material response is the terrain albedo (the ratio of flux density striking the surface to flux density leaving the surface). To be more exact, if the SensorHost provides the IG with material response across NVG sensitive wavelengths, the IG is rendering NVIS terrain albedo (ρ_{NVIS}) with diffuse directionality.

- 3) There exists data describing the performance of NVGs as a function of NVIS Irradiance (NI) incident to the image intensification tube. Performance measurements should include, at a minimum, output luminance as a function of tube input (NI) and noise level as a function of tube input (NI). The NVG Team at AFRL/HEA has collected such data.
- 4) There exists data describing the halo behavior of an NVG as a function of the NVIS Radiance of the light source creating a halo and the total NVIS Irradiance incident on the NVG. The NVG Team at AFRL/HEA is collecting this data.

Algorithm Example. As an example of how NVTS hardware and software work together to facilitate physics-based NVG simulations that meet the accuracy requirements given, a portion of the NVTS algorithm is included. The following is an outline of the mathematical solution for the reflected component of NVIS Irradiance (NI_{goggle}) incident to the aperture of the NVG. The math is followed by a discussion of how the result flows through the system to present the correct image to the human eye.

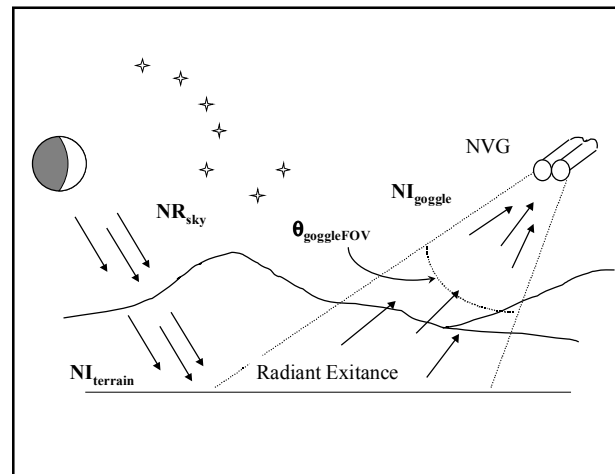

Fig.4 NVTS Environment

GIVEN: $NI_{terrain}$ As per the assumptions described above, we can use $NI_{terrain}$ at the earth's surface as an input to our calculations. Also $\overline{\rho_{NVIS}}$ is derived from output of the NVP and the optical properties of the materials in the terrain database.

WANT: NI_{goggle} As per the assumptions described above, it is radiometric energy at the aperture of the sensor that determines NVG performance. If we can model the NI at the goggle, we can simulate goggle performance using real world data to drive the model. Specifically, we want $NI_{goggle} = f(NI_{terrain})$. The following steps will support that NI_{goggle} may be represented as a function of $NI_{terrain}$ as in Eq. (1).

$$NI_{goggle} = NI_{terrain} \cdot \overline{\rho_{NVIS}} \cdot \sin^2\left(\frac{\theta_{goggleFOV}}{2}\right) \text{ (Eq. 1)}$$

Solving for NI_{goggle} requires intermediate calculations of **Radiant Exitance** and $NR_{terrain}$. These solutions may be found below in Eqs. (2-3).

Radiant Exitance (flux density in W/cm²) is a function of flux density incident to a surface and the reflectivity of that surface:

$$M = E \cdot \rho$$

...where M is radiant exitance, E is illuminance, and ρ is reflectance. Substituting NVIS irradiance for illuminance and $\overline{\rho_{NVIS}}$ for visible reflectivity, we get

$$M = NI_{terrain} \cdot \overline{\rho_{NVIS}} \text{ (Eq. 2)}$$

$NR_{terrain}$ is the measure of radiometric flux density per unit solid viewing angle or radiance leaving the terrain (in W/cm²/sr).

$$L = \frac{M}{\pi}$$

...where L is luminance. Substituting NVIS radiance for luminance, we get

$$NR_{terrain} = \frac{M}{\pi}$$

from Eq (2) above...

$$NR_{terrain} = \frac{NI_{terrain} \cdot \overline{\rho_{NVIS}}}{\pi} \text{ (Eq. 3)}$$

NI_{goggle} is the measure of radiometric flux density incident to the image intensification system in W/cm². The irradiance, at any distance from a uniform extended area source, is related to the radiance of the source and the subtended central viewing angle of the viewer as follows:

$$E = \pi L \sin^2\left(\frac{\theta}{2}\right)$$

...where E is irradiance, L is radiance, and θ is the viewing FOV in radians. Substituting for NVIS units, we get

$$NI_{goggle} = \pi NR_{terrain} \sin^2\left(\frac{\theta_{goggleFOV}}{2}\right)$$

from Eq (3) above...

$$NI_{goggle} = NI_{terrain} \cdot \overline{\rho_{NVIS}} \cdot \sin^2\left(\frac{\theta_{goggleFOV}}{2}\right) \text{ (Eq. 1)}$$

Using NI_{goggle} . Eq. (1) provides (NI_{goggle}), the independent variable that is input to the sensor models. The steps below outline how (NI_{goggle}) is used and how data flows, frame-by-frame, in the SensorHost architecture:

1. **SensorHost** defines $\overline{\rho_{NVIS}}$ for every material in the terrain database and passes them to the IG.
2. The IG renders a 3D scene where terrain "color" represents the albedos defined in the previous step modulated by directional lunar illumination. Because the result is a rendering of albedos and says nothing about the lunar intensity, we still must find out how an NVG would gain such a scene depending on which lunar scenario we are simulating and what noise would be created as a result. The remaining steps address this.
3. The NVTTS Video Processor (NVP) tells the **SensorHost** what the average pixel value is in the current frame. From this value, the **SensorHost** derives the average NVIS albedo of the scene (ρ_{NVIS}).

4. **SensorHost** defines NI_{terrain} as a function of the current simulated lunar scenario using a model derived from real-world measurement. This lookup takes the form of

$$NI_{\text{terrain}} = f(\text{lunar phase, lunar position}).$$

5. **SensorHost** may now calculate NI_{goggle} using (Eq.1) above. This value represents the nominal energy incident to the sensor as a result of lunar energy reflected by the terrain. NI_{goggle} may be further adjusted at this stage by the state of the many parameters communicated by the IG (including battlefield effects in the FOV, emissive light sources in the FOV, the moon in the FOV, etc). Knowing the energy incident on the NVG, **SensorHost** may now calculate the correct tube output, noise level, and halo intensities using a model derived from real-world measurement (See Assumptions above). These lookups take the form of

$$\text{Desired Tube Output (FL)} = f(NI_{\text{goggle}}).$$

$$\text{Desired Tube Noise} = f(NI_{\text{goggle}}).$$

$$\text{Desired Halo Intensity Offset} = f(NI_{\text{goggle}}).$$

6. Using the results of the three lookups above, the **SensorHost** provides the NVP with gain and noise commands which take into account the gamma properties of the HMD to arrive at the desired tube output luminance and noise level. Halo Intensity Offset is communicated to the IG via the **SensorHost** ICD. The IG video, after gained to the correct level and injected with the appropriate noise, produces the correct NVG image in the HMD.

NVTS SensorHost

The AFRL/HEA SensorHost software is hosted on a Pentium Class COTS personal computer running the Linux operating system. Required interfaces to the SensorHost computer include an RS-232 port for NVTS Video Processor (NVP) communication and an ethernet port for IG communication. All SensorHost software is government owned.

NVTS Video Processor

The AFRL/HEA NVTS Video Processor (NVP) is a collection of analog circuits designed and implemented specifically for NVG simulation.

Interfaces to the system include standard analog video inputs and RS-232 ports for **SensorHost** communication. The NVP is government owned.

Conclusion

Research in NVG training requirements and training system technologies has yielded a better understanding of issues regarding NVG training and physics based NVG simulation. Most importantly, it has been found that the fidelity required to support NVG training of sufficient quality is particularly demanding. Training and rehearsal needs collected from the user have pointed out that even very subtle NVG characteristics must be present to properly prepare for the operational environment. This challenge cannot be met with traditional approaches.

Today, physics based simulation of NVGs allows for the highest level of fidelity possible. Advancements in IG technology are supporting sensor simulation techniques of growing complexity allowing rigorous algorithms to be employed. Benefits go beyond that of improved realism and training value. Future applications will require the flexibility that physics based simulation offers including adaptability to different NVG models and advanced fused sensors for which stimulation will not be an option.

Utilizing physics based sensor simulation in real world application has underscored the need for efficient system architectures which allow for technology insertion, software reuse, simplified integration, and system validation at the module level. Many in the training system community have high hopes for low cost IG technologies to provide relief in the face of shrinking budgets for new training systems. Many overlook the fact that integration effort continues to be the primary driver of cost and that IG channels really contribute a minor percentage of the cost of a new training system procurement. Modular system architectures like the NVTS **SensorHost** must be matured and utilized if we are to make high fidelity sensor simulation *more* available to the user.

Appendix: SensorHost ICD

Fig. 5 shows version 2.4 of the **SensorHost** ICD that is updated at IG frame frequency using UDP and ethernet. It contains one buffer each for IG to SensorHost communication and SensorHost to IG communication.

```

////////////////////////////////////// SENSOR ICD 2.4 ////////////////////////////////////////
// sensorICD.h

#ifndef __SENSOR_ICD_H__
#define __SENSOR_ICD_H__

#define SENSOR_ICD_VERSION 2.4

#define SENSOR_ICD_BASE_KEY    0x12345670
#define SENSOR_AG_BASE_KEY     0x12345680

// RANGE
//
// Floating point range for IG computations
//
typedef struct {

    float min;
    float max;

} Range;

// SKY OBJECT
//
// Provides pitch, heading and magnitude of a celestial object for the viewer position
// Typically will be planets and high magnitude stars and galaxies or just the orientation
// of the star field
//
typedef struct {

    float position[3];      // heading and azimuth and roll
    float magnitude;

} SkyObject;

// CELESTIAL TABLE
//   Defines all sky objects to be used for sensor FX
//
//   - Moon phase is encoded on the magnitude [-1.0 to 1.0]
//     o Positive values are "D" (Increasing moon)
//     o Negative values are "C" (Decreasing moon)
//     o +1 and -1 are both full moon, 0 is new moon.
//   - If position is 0,0 the moon is not in the sky
//   - Star Field only uses the heading and pitch
typedef struct {

    SkyObject  moon;
    SkyObject  sun;
    SkyObject  planets[8];

    SkyObject  starField_Polaris;
    SkyObject  starField_NorthPole;

    SkyObject  flirDelayedSun;
    SkyObject  nvgSkyGlow;

} Celestial;

```

Fig 5. SensorHost ICD v. 2.4

```

// THERMAL
//
typedef float Temperature[262144];
typedef float Blackbody[256];

// MATERIAL REFLECTANCE
//
// Provides the floating point reflectance [0-1.0]
//
typedef float Reflectance[256];

// FX FEEDBACK
//
// Returns real time information of visible and near FX in view
typedef struct {

    float inView;
    float near;

} FxCount;

// TIME OF DAY AND DATE INFORMATION
// sent from the IG, echoing the information from the IOS

typedef struct {
    int hour;
    int minutes;
    int seconds;
    int day;
    int month;
    int year;
} TimeDate;

////////////////////////////////////// SENSOR HOST to IG ////////////////////////////////////////

typedef struct {

    // Materials
    Reflectance    reflectance;

    // Enviroment
    float          ambient;
    float          glHumidity;
    float          glAirTemperature;
    float          glAirSpeed;

    // control
    int            terrainShadow;
    Celestial      celestial;
    float          nvgHaloOffset;

    // Auto Gain
    float          sensorGain;
    float          noiseGain;

    // Dynamic range
    float          igGlobalScale;
    float          igVideoScale;

    // OPTIONAL: Thermal
    Temperature    temperature;
    Blackbody      blackBody;

} Sh2IgICD;

```

Fig 5. SensorHost ICD v. 2.4 (cont.)

```

//////////////////////////////////// IG to SENSOR HOST //////////////////////////////////////
typedef struct {

    // date and time of day information
    TimeDate TimeDate;

    // low precission viewpoint in latlong and altitude over sea level
    float viewpoint[3];
    float viewpoint_hpr[3];

    // Genlock
    int   frameNumber;           // frame number for sync sensor host

    // Visibility of Off-Scale sources
    float   haloCount[8];       // [0-16] (maxHalos)
    float   moonVisibility;     // [0-1]
    float   moonShadow;        // [0-1]
    float   sunVisibility;      // [0-1]

    // Fx
    FxCount explosions;
    FxCount fires;
    FxCount plumes;
    FxCount missileLaunch;
    FxCount missileTrail;
    FxCount tracers;
    FxCount flares;
    FxCount lightning;
    FxCount cockpitLights;

    // aux
    int aux;

} Ig2ShICD;

//////////////////////////////////// SENSOR HOST ICD 2.4 //////////////////////////////////////

typedef struct {

    Sh2IgICD   sh2ig;

    Ig2ShICD   ig2sh;

} SensorICD;

```

Fig 5. SensorHost ICD v. 2.4 (cont.)